



**DXF**  
CLAVE

DENTAL EXPERIENCE GETS DYNAMIC

**dxp**  
CLAVE



The most performing experience.





For over 40 years, our brand has been supporting dental and medical professionals by manufacturing products that make every working day easier.

Concreteness, reliability and effectiveness are in our DNA, with usability and dynamism our genetics.

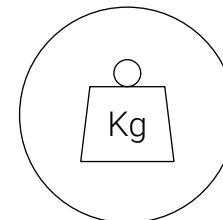

Capacity

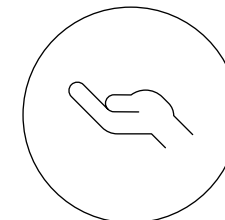

Usability

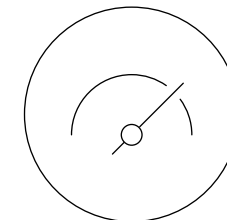

Performance

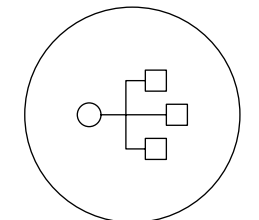

Traceability

#### LOAD CAPACITY

With its **larger load compartment and 5 differentiated trays** designed to improve capacity, the DXPclave allows all useful space to be exploited, guaranteeing the best load capacity in its category (24L). All with optimised full-load cycle times for extreme effectiveness.

#### USABILITY

DXPclave's user interface is designed with a high focus on usability. Thanks to the 4.3" capacitive touch screen display and the **intuitive menu**, cycle selection and programming are simple and instantaneous. A **user-friendly** design then facilitates the work of every professional.

#### PERFORMANCE

The structure of the DXPclave is designed to generate steam quickly and efficiently. Together with the tray system, designed to improve drying, and the **steam generator with stainless-steel coil** to prevent the risk of clogging, it guarantees best-in-class cycle times and long-lasting performance.

#### TRACEABILITY

With DXPclave, sterilisation cycle reports can be automatically saved on USB media. Traceability is optimised thanks to the integrated or external printer. The **native Ethernet connection** ensures compatibility with the web platform and secures storage and analysis of the data.





DXP products come from extensive **experience** in the world of sterilisation. Solid technical, technological and design skills unite to create contemporary, strong and durable products such as the DXPclave, with its robust structure, functional design and a simple and **reliable** manual locking system.

#### CYCLE SPEED AND LOAD CAPACITY

The DXPclave structure is designed to achieve very short cycle and drying times, having **Class B and S rapid cycles** that have a run time of approximately 40 minutes with a typical\* load. Performance is comparable to high-end devices thanks to:

- **new steam generation technology** that ensures extreme heat exchange effectiveness;
- a chamber and hydraulic circuit **design** that ensures a very fast cycle start-up and an extremely efficient vacuum phase;
- a **tray designed** for high heat transfer.

Speed and efficiency are also guaranteed by the capacity of the load compartment. The usable space inside the chamber is optimised and the trays are differentiated so that the entire space can be utilised. This results in a load capacity of up to 7 kilograms at maximum capacity, at the top of the category.

\*Typical load of 2 kg.





2 Characteristics

DXPclave's latest-generation steam **technology** combines with the utmost convenience to ensure that all professionals can work in comfort and with the greatest results. Silent and user-friendly, it stands out thanks to its capacity and **design**, becoming a reliable and effective ally.



**DRAINAGE SYSTEM**

DXPclave is equipped with a **single drainage system** for clean and waste water. This solution offers greater convenience than traditional systems, as the integration of a single tap allows both tanks to be emptied from the same system, without having to connect a tube to two different outlets.

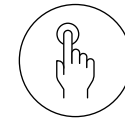

**TOUCH DISPLAY**

The 4.3" colour touch display is easy to use thanks to a **clear and intuitive menu**. What's more, it is easy to clean and maintain as well as being capacitive and even responsive when wearing gloves. It allows you to **schedule** the sterilisation cycle start-ups and **testing**, whilst immediately reporting the status and steps of the cycles through a user-friendly interface.

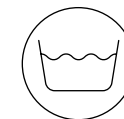

**WATER LOAD COMPARTMENT**

Resistant to cleaning agents, it is **designed for easy cleaning**, starting with a removable and replaceable filter without requiring any dismantling of machine parts. The tank is also equipped with level sensors with no moving parts, ensuring both **easy sanitation** and greater reliability, along with eliminating the chance of mechanical part failures.



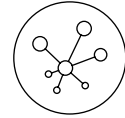

#### NATIVE ETHERNET CONNECTION

The native Ethernet connection ensures **full compatibility with a web platform** to allow automatic storage and analysis of the data.

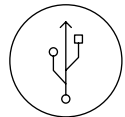

#### USB

The integrated USB port allows you to connect storage media for complete traceability of cycles and tests in accordance with current regulations. The set-up is also designed to **connect an external printer for labels or cycle reports**.

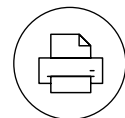

#### INTEGRATED PRINTER

DXPclave comes with an integrated printer for generating **quick and immediate report printouts** regarding the sterilisation cycles and tests, for easy and complete traceability and archiving.



**DXP**  
CLAVE

Technical data and accessories



3 Technical data

SIDE VIEW

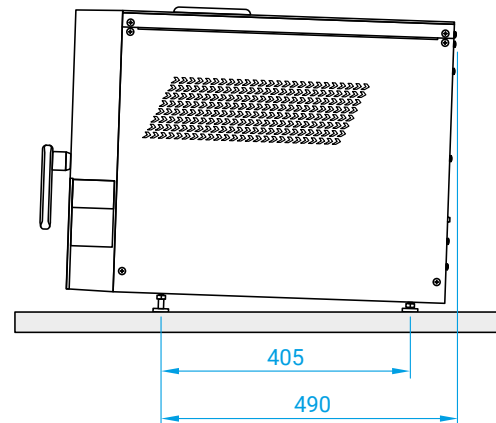

FRONT VIEW

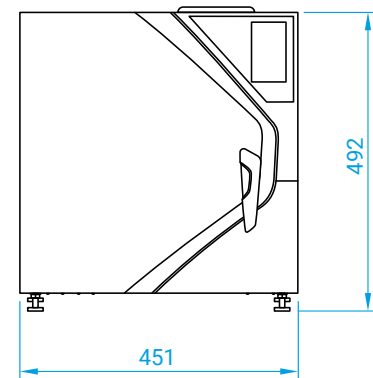

TOP VIEW

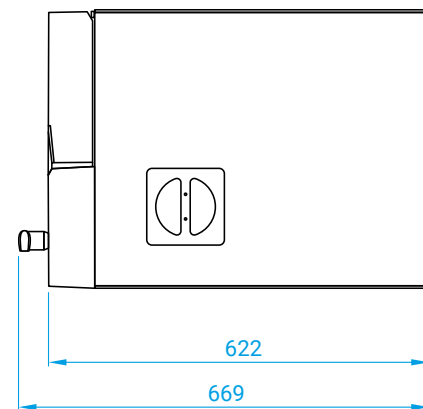
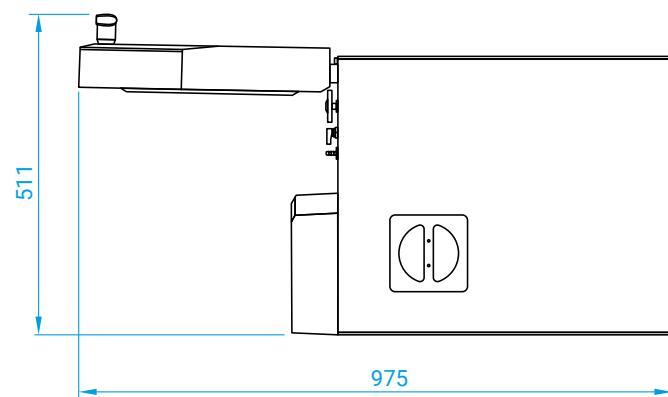

Safety devices

- Protection from electricity blackout
- Protection from short-circuit
- Protection from overheating
- Protection from overpressure
- Protection from accidental door opening

- Process evaluation system
- Real-time autodiagnosis system
- Adaptive Heat System

Certifications

- Class IIa medical device compliant with Reg. MDR. 2017/745 / EU (rule 16)
- Chamber complies with Directive 2014/68/ EU
- Company: ISO 9001 - ISO 13485

Main compliances

- EN 13060
- IEC 61010-1
- IEC 61010-2-040
- IEC 61326-1
- EN 13445

International standard.

Intended use

DXPclave is a small steam sterilizer used to sterilize medical devices or for materials that are likely to come into contact with blood or body fluids. According to requirements of EN 13060:2014+A1:2018 it is suitable for following sterilization cycle types and loads:

**Type B** Sterilization of solid products, porous products and lumen devices, wrapped or non-wrapped as represented by the test loads.

**Type S** Sterilization of non-wrapped solid products.

STERILIZATION CYCLES DXP CLAVE

CYCLE	TEMPERATURE	STERILISATION	DRYING	MAX. LOAD	TYPICAL LOAD CYCLE TIME 2KG	FULL LOAD CYCLE TIME
B <sup>U</sup>	134°C	4'	10'	7 kg	40 min	55 min
B <sup>P</sup>	134°C	18' 30"	16'	7 kg	59 min	70 min
B <sup>F</sup>	134°C	3' 30"	5'	2 kg	n/a	38 min
B <sup>121</sup>	121°C	20' 30"	18'	7 kg	60 min	76 min
S <sup>F</sup>	134°C	3' 30"	7'	2 kg	n/a	32 min

Cycle times may vary depending on the type and weight of the load, temperatures and mains voltage.

TECHNICAL CHARACTERISTICS DXP CLAVE

CHARACTERISTICS	DXP CLAVE
OVERALL DIMENSIONS	451 x 492 x 669 mm (L x H x D)
CHAMBER DIMENSIONS	∅ 265 - 475 mm (D)
CHAMBER VOLUME	24 L
WEIGHT (no load)	61 kg
POWER SUPPLY VOLTAGE	230V ~ 50/60Hz
CONSUMPTION (power)	2350 W
CICLE WATER CONSUMED	700 cc ÷ 800 cc
TANK CAPACITY (clean water and used water)	5,7 litres each
AUTOMATIC STANDBY	After 5' of inactivity
SOUND EMISSION	57dB

Water should fulfill the EN 13060 Annex C requirements.

4 Equipment and codes



**92411B0100**  
→ DXPclave 24 No Printer



**92411B0100P**  
→ DXPclave 24 Printer

Documentation supplied

- Declaration of Conformity for the device
- Declaration of Conformity for the chamber
- Test Report

- User Manual
- Quick Guide

5 Accessories



**OPTIONAL PRINTER**

Optional external, affordable and compact printer, ideal for printing sterilisation cycle data on paper or adhesive labels. It comes with a USB and power supply cable.



**HELIX TEST**

This test facilitates verification that steam has penetrated a hollow body. The test consists of a tubular plastic device with an indicator vessel at the end, supplied with 250 control indicators, being easy to interpret and compliant with EN 867-5.



**DX425**

A water treatment system that demineralises water from the regular mains, rendering it suitable for use in autoclaves.







CE  
0123

DXP-STERILIZATION.COM

**dxp** **EN**

NSK Dental Italy S.r.l.  
Via dell'Agricoltura, 21  
36016 Thiene (VI) Italy  
t. +39 0445 820070



KFADV.IT

© NSK Dental Italy S.r.l. - All rights reserved. 02/2023 CA5018EN rev01  
NSK Dental Italy S.r.l. reserves the right of modifying characteristics and/or details of the products introduced hereunder, without previous notice. Therefore the products can result lightly modified compared to the pictures.